

# SCAMBIATORI A PIASTRE ISPEZIONABILI GASKETED PLATE HEAT EXCHANGERS

## PHE FL+

Connessioni/Connections: DN150 ÷ DN500  
Superficie piastra/Plate surface: 0,400 ÷ 3,0

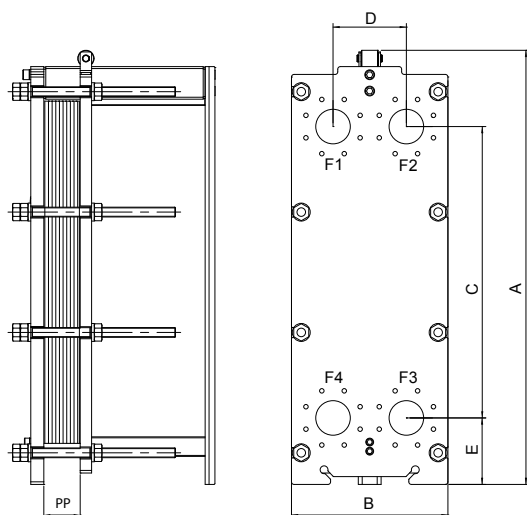

### CARATTERISTICHE / FEATURES

Modello	Diametro connessioni	Superficie piastra m <sup>2</sup>	Press. max di esercizio bar	A	B	C	D	E	PP
				mm					
F41	DN150	0,400	16	1470	620	941	290	290	NPx3,5
F60	DN150	0,600	16	1836	620	1306	290	290	NPx3,5
F80	DN150	0,800	16	2200	620	1671	290	290	NPx3,5
F112	DN150	1,120	16	2687	620	2157	290	290	NPx3,5
F405	DN200	0,410	16	1380	760	770	395	395	NPx3,1
F70	DN200	0,680	16	1740	760	1130	395	395	NPx3,1
F100	DN200	1,000	16	2100	760	1490	395	395	NPx3,1
F130	DN200	1,300	16	2460	760	1850	395	395	NPx3,1
F81	DN300	0,800	16	930	980	1100	480	480	NPx3,8
F120	DN300	1,200	16	2320	980	1490	480	480	NPx3,8
F160	DN300	1,600	16	2710	980	1879	480	480	NPx3,8
F190	DN300	1,900	16	3100	980	2267	480	480	NPx3,8
F150	DN500	1,500	16	2500	1370	1466	672	672	NPx4,1
F200	DN500	2,000	16	2855	1370	1822	672	672	NPx4,1
F250	DN500	2,500	16	3211	1370	2178	672	672	NPx4,1
F300	DN500	3,000	16	3567	1370	2534	672	672	NPx4,1

Model	Couplings diameter	Plate surface m <sup>2</sup>	Max working pressure bar	A	B	C	D	E	PP
				mm					

SERIE PHE FL+