

SCAMBIATORI A PIASTRE ISPEZIONABILI GASKETED PLATE HEAT EXCHANGERS

PHE FL

Conessioni/Connections: DN100
Superficie piastra/Plate surface: 0,210 ÷ 0,710

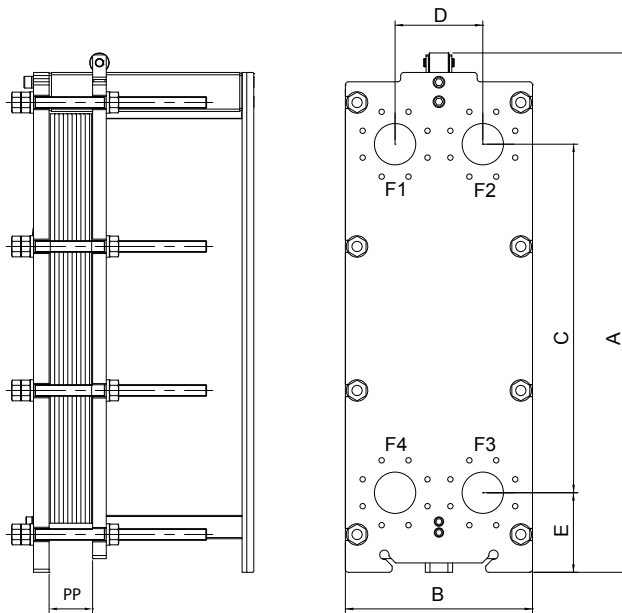

CARATTERISTICHE / FEATURES

Modello	Diametro connessioni	Superficie piastra m ²	Press. max di esercizio bar	A	B	C	D	E	PP
				mm					
F206	DN100	0.210	16	1160	480	719	225	225	NPx3,1
F31	DN100	0.300	16	1132	480	894	225	225	NPx3,1
F50	DN100	0.500	16	1826	480	1388	225	225	NPx3,1
F71	DN100	0.710	16	2320	480	1882	225	225	NPx3,1

Model	Couplings diameter	Plate surface m ²	Max working pressure bar	A	B	C	D	E	PP
				mm					

SERIE PHE FL